

Dessa ritningar är ERGONOMIX AB:s egendom och skyddad enligt tilläggade lag samt får ej utlämnas, kopieras, delges, anman eller obehörigen användas.  
 These documents must not be copied without ERGONOMIX AB's written permission and contents thereof must not be imparted to a third party nor be used for any unauthorized purpose. Contravention will be prosecuted.

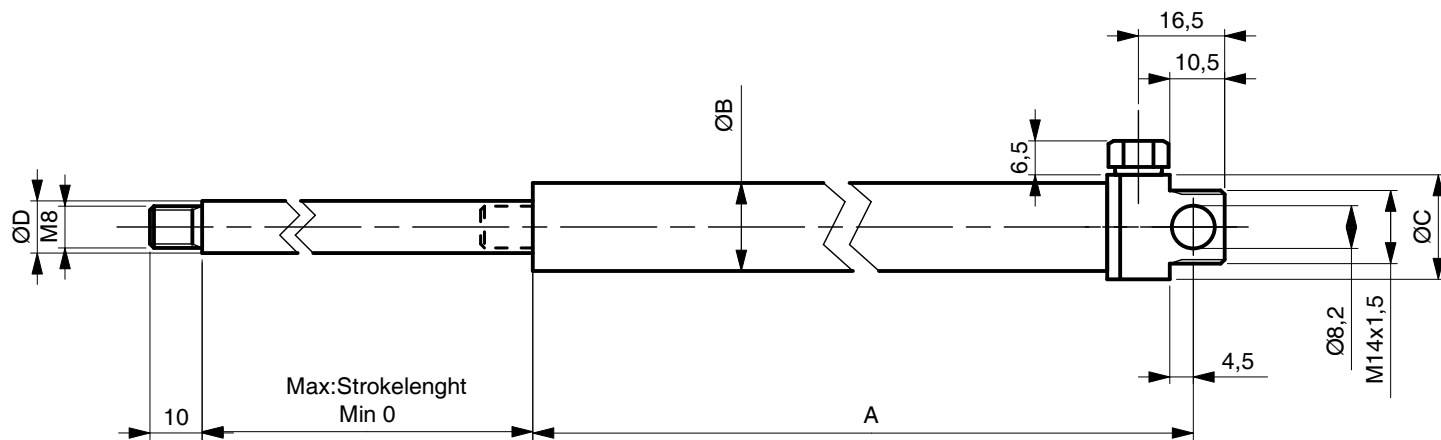

Articel nr.	Ind.	Stroke	A	B	C	D
AS1150		150	207	14,5	20	10
AS1212		212	269	14,5	20	10
AS1300		300	357	14,5	20	10
AS1424		424	481	14,5	20	10
AS1505		505	569,5	14,5	20	10
AS1600		600	672	14,5	20	10
AS2150		150	207	17	20	10
AS2212		212	269	17	20	10
AS2300		300	357	17	20	10
AS2424		424	481	17	20	10
AS2505		505	569,5	17	20	10
AS2600		600	672	17	20	10
AS3150		150	207	20	20	10
AS3212		212	269	20	20	10
AS3300		300	357	20	20	10
AS3424		424	481	20	20	10
AS3505		505	569,5	20	20	10
AS3600		600	672	20	20	10
AS4150		150	222	23	23,5	12
AS4212		212	284	23	23,5	12
AS4300		300	372	23	23,5	12
AS4424		424	496	23	23,5	12
AS4505		505	577	23	23,5	12
AS4600		600	672	23	23,5	12

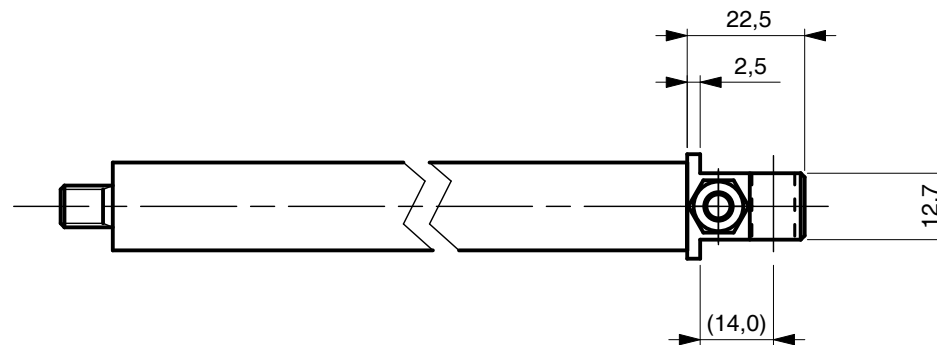

**Note! Do NOT fasten the cylinder rigidly in both ends, since this can effect the return stroke of the cylinder**

		Ritn. storlek Drwg size <b>A3</b>	Skala/Scale <b>1:1</b>	E	Material
		Ritad av-Datum/ Drawn by-Date <b>JÖS 080226</b>	Godkänd av-Datum/ Approved by-Date		Benämning/ Description <b>AS-cyl</b> Build in cylinder for D1 - D4
<b>Ergonomix AB</b>		Erätter/Replaces	Erstatt av/Replaced by	Ritn. nr./Drwg no. <b>11029</b>	Index